



61  
YEARS

# SKYHOOK

A quarterly newsletter  
published by the Skywide  
Amateur Radio Club  
located in Etobicoke area  
of Toronto Ontario

Autumn 2011

## Larry's Saga Continues



**Boxing day** came and my Dad helped me carry the kit downstairs and I started to work on it. I don't remember how long it took me to build it, but I finally finished it. My uncle agree to help me do a final inspection, looking for bad soldering connections, etc. Using a 60 watt light bulb he also taught me how to tune up the transmitter. (To those who have been licenced since the 80's, tuning up a tubed transmitter is somewhat more difficult than tuning up a more modern transistorized transmitter).

My antenna was a 75 foot random wire. Somewhat shorter than 1/2 of an 80 meter dipole. Because it is not the correct length, I had to couple it to my transmitter in order that the transmitter would 'think' it was the correct length. There are various types of antenna couplers. My antenna coupler was a simple series tuned circuit using a variable capacitor and various coils. Because I could not afford the luxury of an SWR bridge, my uncle showed me how to use a neon lamp.

As I tuned the various controls, the neon lamp would change its brilliance. The brighter the better. My transmitter and antenna coupler were tuned. I had to make sure that the transmitters final amplifier's tuning control was always at its proper settings.

Everything was ready for my first contact.

I listened and heard a CQ. I rotated the transmitter switch to operate and rotated the antenna switch and started to tap on the key to sent out his call sign. When I pressed the telegraph key I got a strange sound back. I was expecting a tone back, but instead got a loud thump sound from the receiver. I released the key and got the same thump sound. Something was wrong! I did the same thing again with the same result. I was puzzled. What was wrong? I sat back and thought for a few seconds and realized that I was not turning off or muting my receiver. So I switched the receiver's function to standby and tried again. This time no sound. The only sound I could hear was the mechanical sound of the key when the contact was made.

## The "Skywidiers"



Don Weekes VE3PVA

### In This Issue:

Larry' Saga	1
Wanna Tinker?	2
Club Page	4



I stopped for a bit to redirect my thinking. My first realization was that I needed some way to monitor my transmission. Besides being common sense, I remembered that it was also part of the radio regulations that we are able to monitor our transmissions. I had to do it.

My first thought was to connect my code practice oscillator to my transmitter key. I put my transmitter to transmit mode and measured the voltage across key terminals. It was -65 volts. Too high! The code practice oscillator was made of 1 transistor and 6.3 volt filament transformer. My code practice oscillator ran on 9 volts. Bring in -65 volts would probably have "fried" the oscillator. So that idea was not worth investigating.

What next?...

My next idea centered around the receiver itself. I opened the assembly book of my GR-91 receiver. I started to look at the first RF amplifier and, in particular, the cathode to ground connection. I reasoned it out that if I disconnected the cathode, that tube would stop functioning.

.....  
*Larry's Saga will continue in the Winter 2011 issue*





### 80 Meter Band Conversion Receiver

(Part 9)

I've received several questions about the audio oscillator shown in Figure 2 (which should have been labeled Figure 1) in article #4. A corrected drawing of the audio oscillator is shown below. Notice that the shell of the RCA type output jack (Radio Shack #274-346, or equivalent) is connected to ground. **Figure 1**

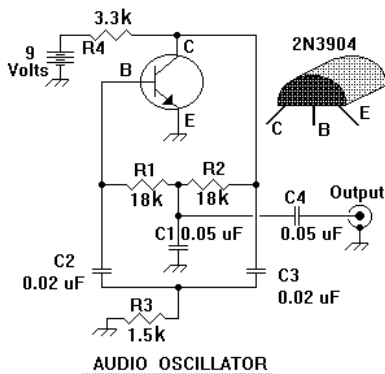

Now that you have built an audio amplifier and audio generator (you DID build them, didn't you!?) here's a "front end" that completes your 80 meter direct conversion receiver. "What is a Direct Conversion receiver?" you might ask. Excellent question! A DC receiver is a circuit that takes a radio frequency (RF) signal from the antenna and converts it DIRECTLY into audio signals that you can hear, without going through an intermediate frequency (IF) circuit. (don't worry about IF circuits right now; we'll cover them in the 40 meter receiver.)

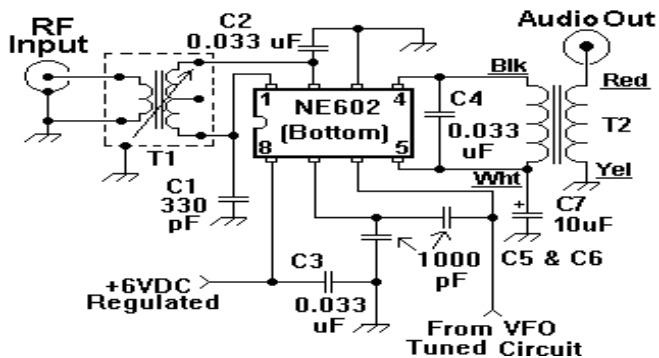

80 METER DIRECT CONVERSION (DC) RECEIVER

Figure 2

A parts layout for the 80 meter receiver is shown in Figure 3. I used a socket rather than soldering the NE602 directly into the circuit. I recommend you do the same. This allows you to do voltage and resistance checks **before** plugging in the NE602. Notice that the ground end of R2 is soldered to the case (shield) of L1. Notice, also, there is a wire connecting the case of T1 to the case of L1. Use #20, or larger copper wire. The cases of both T1 and L1 must be soldered to ground at their mounting tabs.

### 80 METER RECEIVER PARTS LAYOUT

Figure 3

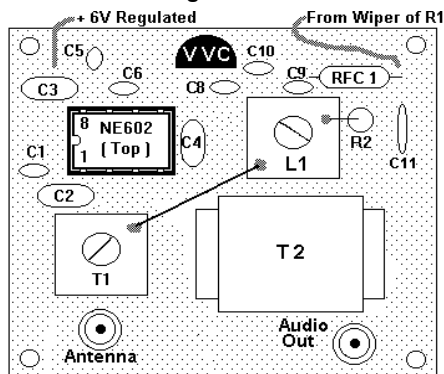

Speaking of "ground", it is, of course, simply the common connecting point that provides a return path for all circuits. It is good practice to keep all ground connections as short as possible, particularly when working with radio frequency (RF) circuits. Connections between modules must always include at least **TWO paths**: one for the **SIGNAL** and one for **GROUND**. There can be other connections between modules, such as main **power** (usually 12 volts), **regulated voltages**, and control signals for **switching, keying, etc.** I always use miniature coaxial cable for signal connections, and ordinary hookup wire for other connections. It is also good practice to use miniature coaxial cable or a "twisted pair" for connections to potentiometers. I sometimes use three braided wires to pots: top of the pot, wiper, and ground. This serves to keep the wiring neat and orderly as well as providing some shielding, with the ground wire woven in with the two signal carrying wires.

This 80 meter receiver will become the **product detector** in the superheterodyne receiver section of a **40 meter transceiver** with an intermediate frequency (**IF**) of **3.5795 MHz**. Why 3.5795 MHz? Because I have a box full of 3.5795 MHz crystals salvaged from TV sets (also, 3.58 MHz crystals are cheap, even if you buy them new). These crystals can be used to make filters for an IF circuit operating at 3.5795 MHz. There is method to this madness, trust me!



Some may question an IF in the middle of the 80 meter band, but how many signals have you heard lately around 3.58 MHz? Not many, I would guess. There may be an occasional "color burst club" QRP signal (like the one we are going to put on the air a few articles down the road) and you may hear the color burst oscillator in your TV set (if you listen VERY carefully). But, I'm getting ahead of our current story; back to the task at hand ...

This receiver is designed to cover only about 2 KHz in the 80 meter band. The frequency is determined by the input transformer resonant circuit (see Figure 2) and the VFO tuned circuit (see Figure 4). T1 is an IF transformer that is normally used in an FM receiver: part number 42 IF 123 from either DC Electronics or MOUSER Electronics. Another IF transformer (same part number), is used as L1 in the VFO resonant circuit but the primary is not used, as shown in Figure 4.

Notice the "+9V Regulated" coming to R1, the tuning potentiometer. Tightly **regulated voltage** is a "MUST"; the slightest variation in the voltage will change the frequency of the VFO.

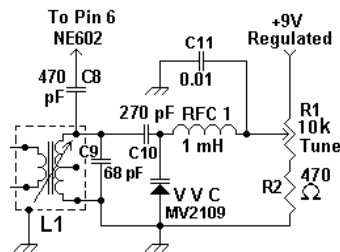

Figure 5

I choose to put the voltage regulation

circuits on a separate board, as shown in Figure 6. There are two reasons for doing this: First, there will be additional regulated voltages required for the transceiver, and if these circuits are put on a separate board, you don't have to worry about fitting them into the various "functional" circuits. Second, voltage regulation circuits can generate heat, and it is a good idea to keep heat generating circuits away from "functional" circuits. If you choose to put your regulation and distribution circuits on a separate board, leave room for a couple more regulator circuits.

A reminder: This "receiver" is really the Product Detector/Audio section of the 40 meter transceiver we are working toward, and the VFO shown here will become the **Beat Frequency Oscillator (BFO)** in the transceiver. For those who may not know about BFOs, you can think of them as the predecessor to what is now commonly called Receiver Incremental Tuning (RIT). RIT (or "clarify", as it is called on some equipment) allows you to tune the receiver without changing the transmitter frequency. On some rigs, you will also find transmitter incremental tuning (XIT), which allows you to tune the transmitter without changing the receiver frequency.

In spite of it's simplicity, this is a "real"

receiver. If you are an eighty meter fan, you can broaden the band-spread and have a good receiver for the whole band. There may be some "old timers" out there who find it hard to believe that this tiny, simple looking circuit can produce good results. All I can say is: Try it; you will be amazed. Then, stay tuned, it gets even better!

The receiver's voltage regulation and distribution circuit is shown in Figure 5. D1 is an optional component that protects against inadvertently reversing the power supply leads. Parts layout is not critical.

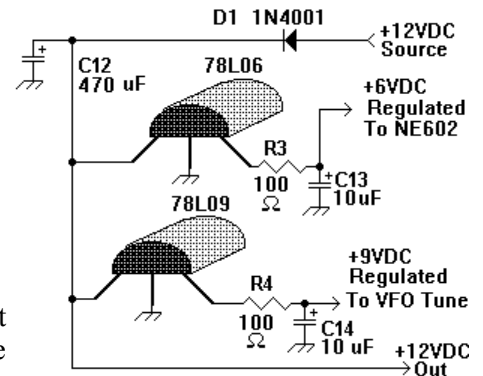

Figure 6

In order to check out this 80 meter receiver, you need a signal generator to provide a 3.58 MHz signal. You can use a "real" signal generator, a grid dip oscillator (GDO), or a

low power transmitter as a signal source. In keeping with the "start from scratch" philosophy of this series of articles, I will assume that you do not have a signal generator. Accordingly, the next article will be devoted to building and testing a crystal controlled signal generator.

Speaking of starting from scratch, it is a great concept on paper, but, like many other concepts, it runs into trouble in the real world. You probably don't have, nor would I expect you to buy test equipment for checking the modules in this series of articles. You will, however, need a good **general coverage receiver**, preferably a "communications - type" receiver with digital readout, or a well calibrated analog dial. If you don't already have such a receiver, get one, or arrange to borrow one from a friend for testing purposes.





### Executive 2010 - 2011

*President:*  
**DEWDNEY, Gord VE3HBG 416-738-1392**

*Past President:*  
**SHIELDS, Jim VE3HCS 416-239-4092**

*Vice-President:*  
**BARANOWSKY, Julian VE3ROZ 416-245-9684**

*Treasurer:*  
**ALLEN, Larry VE3FXQ 416-740-1939**

*Membership Secretary:*  
**ALLEN, Larry VE3FXQ 416-740-1939**

*Skyhook Editor:*  
**BARANOWSKY, Julian VE3ROZ 416-245-9684**

*Technical:*  
**DEWDNEY, Gord VE3HBG 416-738-1392**  
**TEDESCO, John VE3FVR 416-259-4551**

*Awards & ARES:*  
**SHIELDS, Jim VE3HCS 416-239-4092**  
**KING, James VE3ETZ 416-245-4730**

*Health & Welfare:*  
**TRAYES, Jim VE3FMT 416-231-8701**

### SKYHOOK

*Published quarterly by the Skywide Amateur Radio Club;  
 Mailings: Skywide ARC c/o Larry Allen, VE3FXQ,  
 16 Lovilla Blvd, Weston ON M9M 1C5*

Website: <http://jproc.ca/sarc>  
 (Courtesy of Jerry Proc VE3FAB)

*Editor:*  
**BARANOWSKY, Julian VE3ROZ 416-245-9684**

*Mailing & Distribution:*  
**KUKAY, Norm VE3MUM 416-244-6568**

### CLUB MEETINGS

*2nd Monday of each month at 1930 hrs  
 Westway United Church 8 Templar Drive  
 Etobicoke Ontario*

*12 September 2011 24 October 2011  
 11 November 2011 12 December 2011*

#### SKYWIDE AMATEUR RADIO CLUB

**VE3SKY VA3SKY**  
**VE3SKI VA3SKI**

### CLUB NETS

**3.733 MHz or 3.745 MHz Sunday 1000 hrs**  
**7.080 MHz Alternate Morning frequency**  
**146.985 MHz VA3SKY ARES Net 1900 hrs**  
*Non-Meeting Mondays*

**Seniors' Coffee Break - Tuesdays 0830 hrs**  
**At McDonalds, 2116 Kipling Ave.,**  
**(North of Rexdale Blvd)**

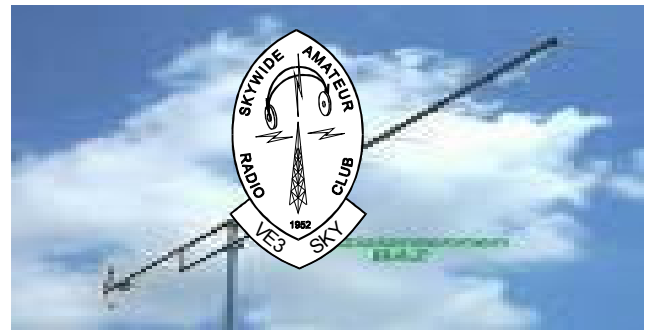

#### 34TH Annual London Amateur Radio Club 2011 Flea Market

London Amateur Radio Club (LARC)  
 Starts on Sunday, September 25, 2011  
 London, Ontario

#### YORK REGION ARC HAMFEST 2011 -

York Region ARC  
 Starts on Saturday, November 5, 2011  
 Markham, Ontario

#### HARC Hamfest (Ancaster)

Hamilton Amateur Radio Club  
 Starts on Saturday, October 15, 2011  
 Ancaster Ontario

#### YORK REGION ARC HAMFEST 2011 - 35th Edition

York Region ARC  
 Starts on Saturday, November 5, 2011  
 Markham, ON

**CHANGED YOUR ADDRESS,  
 TELEPHONE NUMBER  
 AND/OR E-MAIL???**

**If so, please advise Julian Baranowsky,**

**VE3ROZ**

**[jbaranowsky@sympatico.ca](mailto:jbaranowsky@sympatico.ca)**

**In order to have our records updated**

